



German Sd.Kfz.181 PzKpfw VI Tiger Ausf. E Heavy Tank **Early Production** MP-912043C

INSTRUCTION MANUAL

- BEDIENTUNGSANLEITUNG
- MANUALE D'ISTRUZIONI
- MANUEL D'INSTRUCTIONS
- 取扱説明書
- 使用说明书

1:32 SCALE TANK SERIES

ABSC DIE CAST METAL

⚠ Safety precaution • Sicherheitshinweise • Precauciones de seguridad • 安全須知

- UK** This product is not a toy and is sold as a collectible only. It is not suitable for children under 14 years of age. Some parts may contain die-cast metal or plastic parts with fine detailed points or edges. Colors and decorations may vary. Please keep this instruction for future reference.
- DE** Dieses produkt ist kein spielzeug und wird nur als sammlierstück verkauft. es ist nicht für kinder unter 14 jahren geeignet. Einige modelle können metall-oder kunststoffteile mit feinen, detaillierten spitzen oder kanten enthalten. Farben und dekorationen können variieren. Bitte bewahren sie die verpackung für spätere kontaktaufnahme auf.
- IT** Prodotto di collezionismo, non adatto ai bambini di eta' inferiore ai 14 anni. alcuni modelli possono avere parti appuntite o taglienti. Dai 14 anni in su. Metallo die-cast con elementi in plastica. I colori e le decorazioni possono variare. Conservare l'imballo per referenza futura.
- FR** Ceci est un veritable modele echelle et ne pas un jouet. Une piece de collectionneur et ne convient pas aux enfants au dessous certains modeles peuvent contenir des pointes ou bords detaillés et aceres. Au-dessus de 14 ans. Die cast metal injecté avec des parties plastiques. Les couleurs et les decorations peuvent varier.
- ES** Este producto no es un juguete y se vende solo como coleccionable. No es adecuado para niños menores de 14 años. algunos modelos pueden contener piezas de metal fundidas a presión o plástico con detalles finos o bordes. Colores y decoraciones pueden variar. Por favor guarde los detalles para referencia futura.
- JP** この製品はコレクター向けであり玩具ではありません。対象年連 14歳以上製品にはダイキャストまたはプラスチック製の鋭い部品が含まれます。塗装と装飾は参考です。実際の製品と異なる場合があります。
- CN** 此产品是仿真模型收藏品，其中一些合金或塑胶部份可能会含有较为锋利的棱角，不适宜14岁（包含14岁）以下的儿童使用。所有产品的颜色只供参考。

Parts • Packungsinhalt • Contenido del paquete • 包装内容

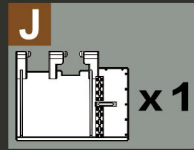
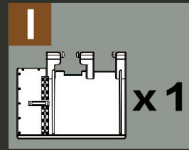
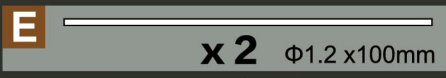
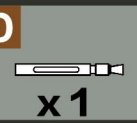
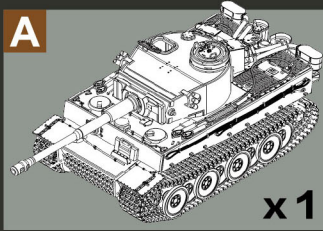

x1

REMOVE THE TANK FROM THE PLATFORM

• ENTFERNEN SIE DEN TANK VON DER PLATTFORM • 从底台把坦克拆除
• RETIRE EL TANQUE DE LA PLATAFORMA

1

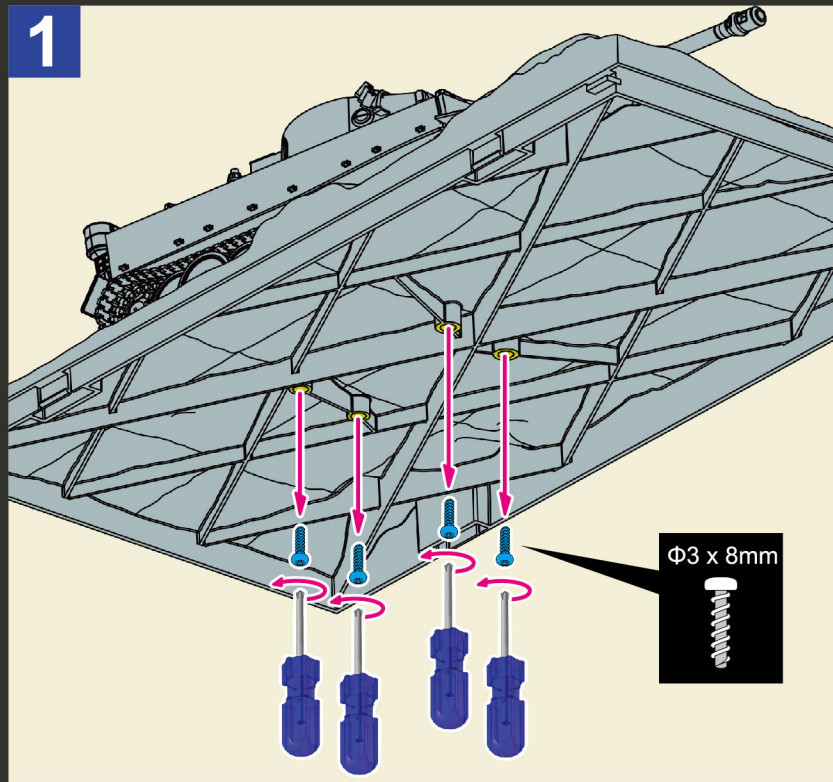

2

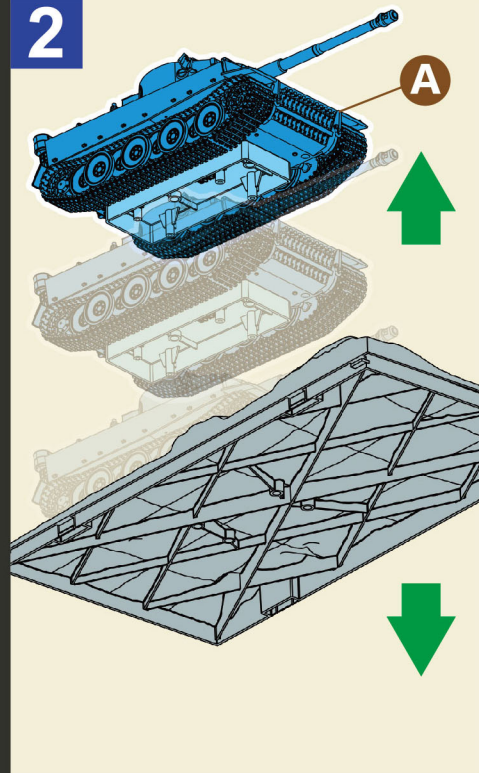

3

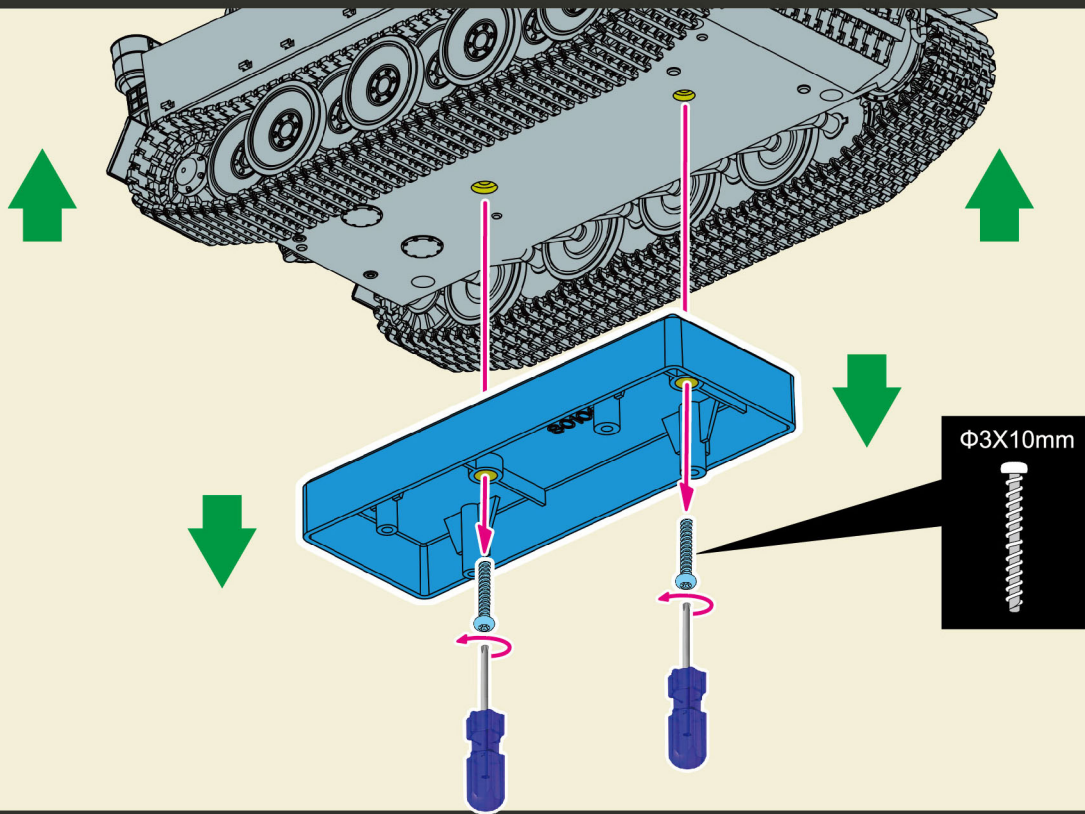

START TO ASSEMBLE

• BEGINNEN SIE MIT DER MONTAGE • 开始组装
• EMPEZAR A MONTAR

4

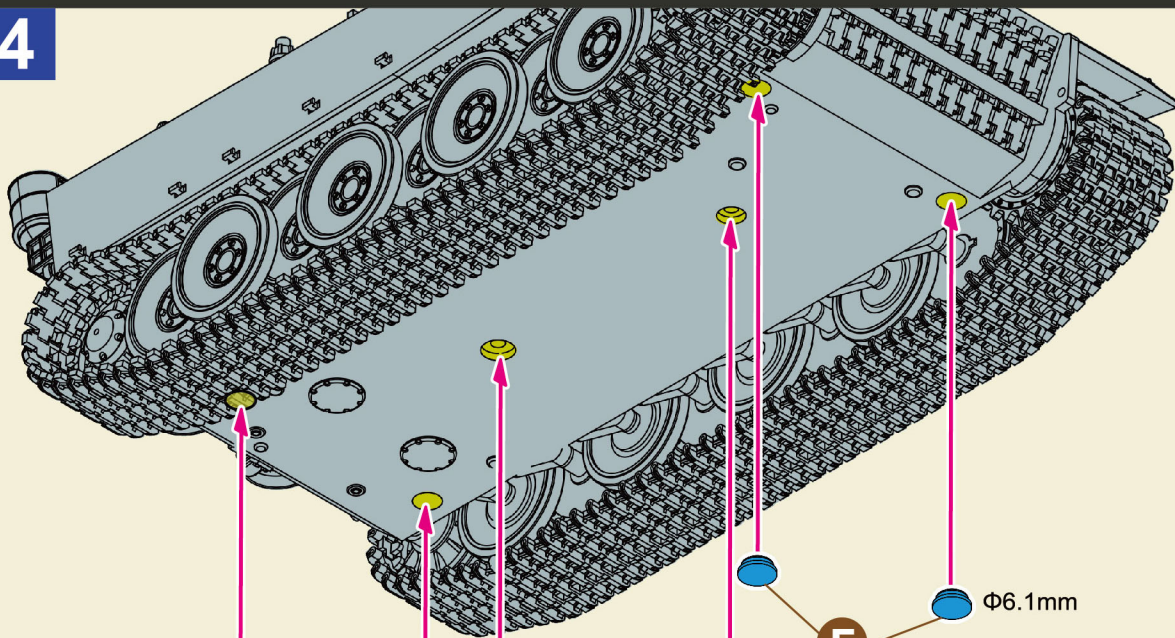

$\Phi 6.1\text{mm}$

F

$\Phi 6.1\text{mm}$

H

$\Phi 5.3\text{mm}$

G

$\Phi 6.1\text{mm}$

F

5



- Note direction.
- Achten Sie auf die Richtung
- Dirección de la atención.
- 注意方向。

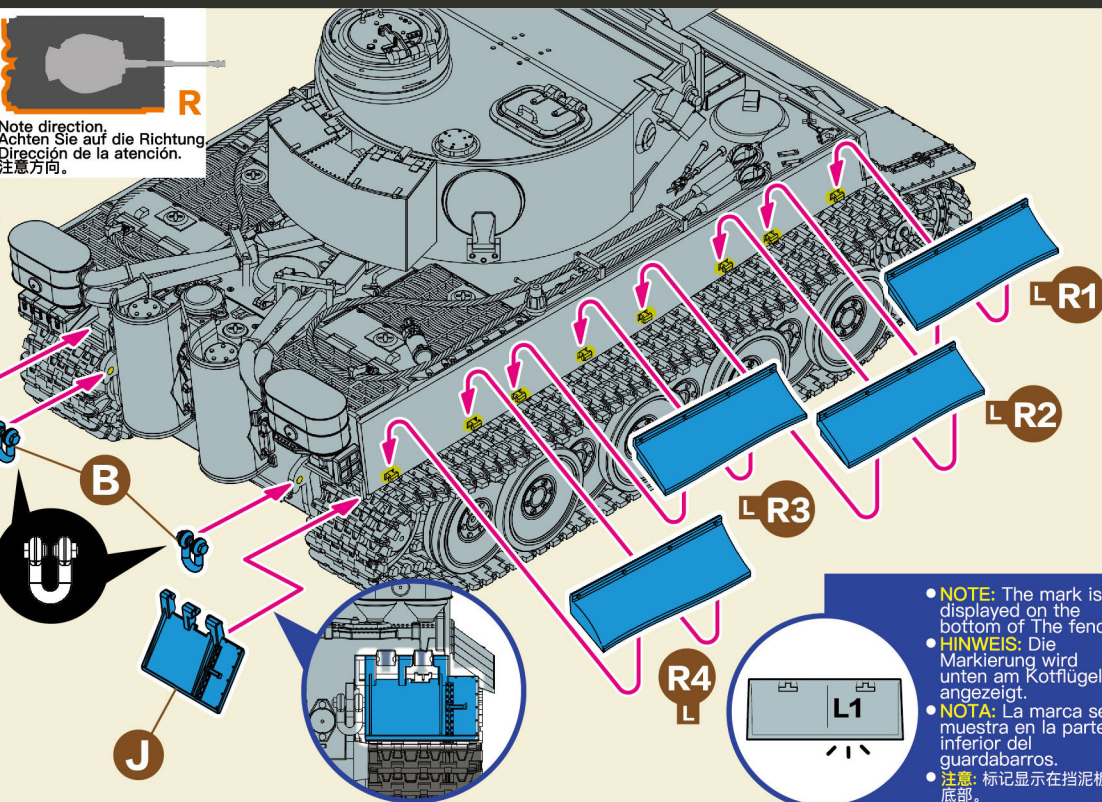

- **NOTE:** The mark is displayed on the bottom of the fender.
- **HINWEIS:** Die Markierung wird unten am Kotflügel angezeigt.
- **NOTA:** La marca se muestra en la parte inferior del guardabarros.
- **注意:** 标记显示在挡泥板底部。

6

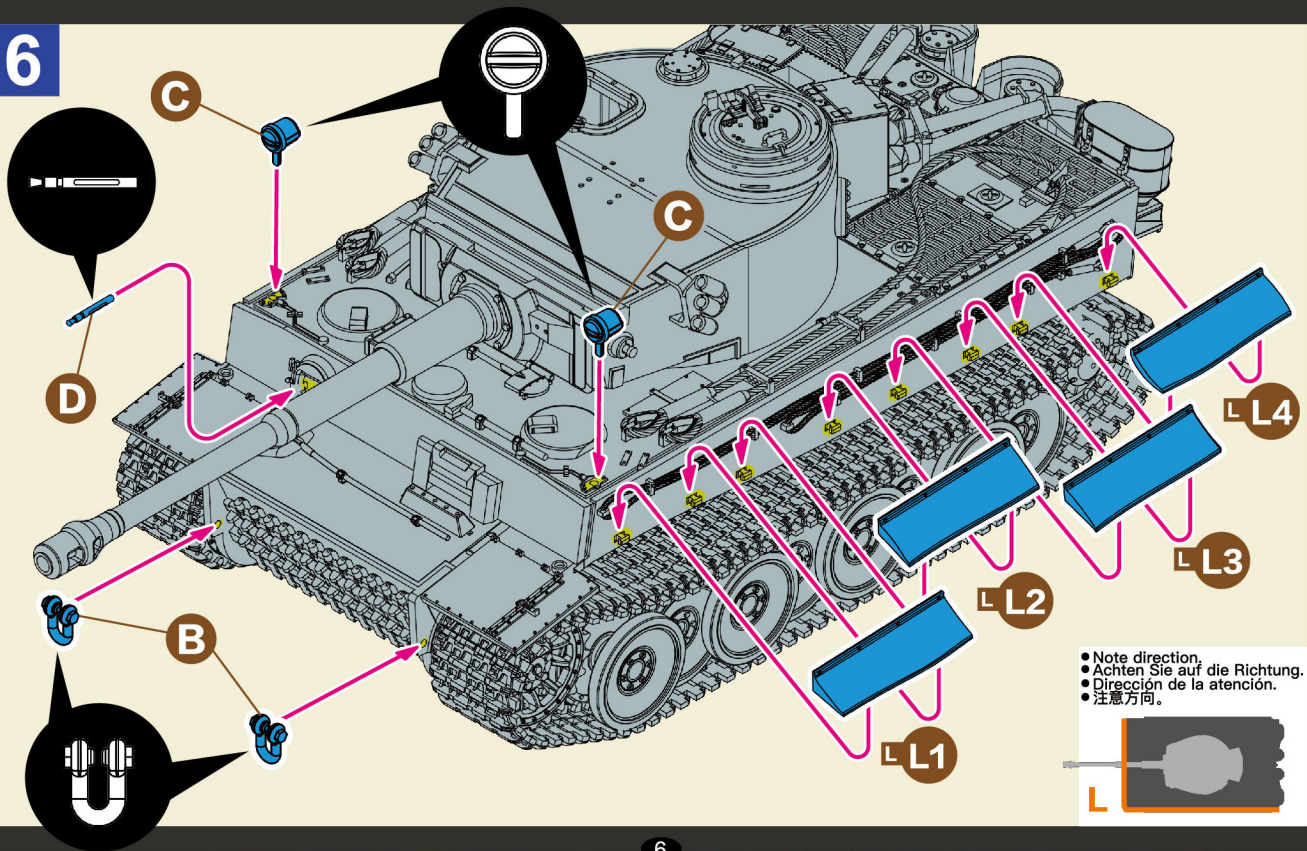

7

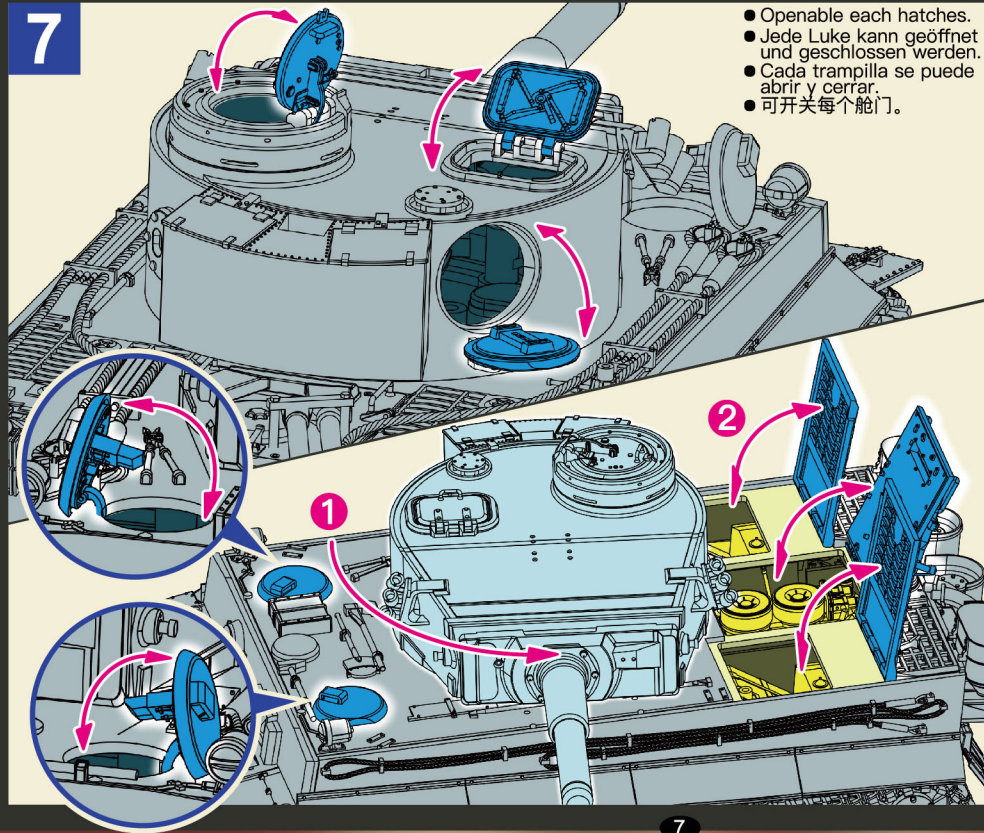

- Openable each hatches.
- Jede Luke kann geöffnet und geschlossen werden.
- Cada trampilla se puede abrir y cerrar.
- 可开关每个舱门。

8

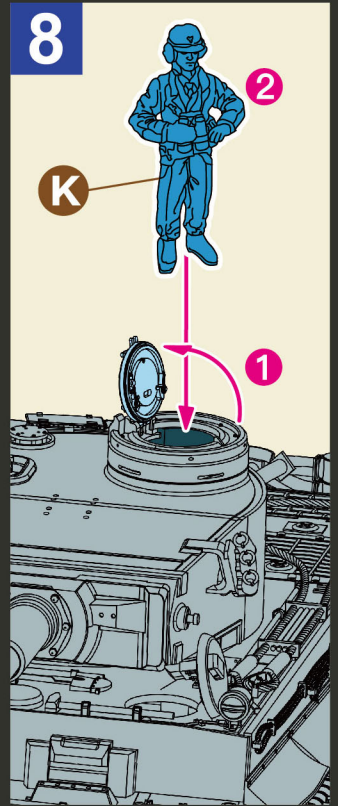

SAGGING EFFECT OF TRACK

Optional Assembly

• KETTEN DURCHHÄNGENDER EFFEKT (Optionale Montage) • 履帶下垂效果(可选择组装)
• EFECTO DE CAIDA DEL TRACTOR ORUGA (Montaje Opcional)

- By using steel axle to press the track to achieve the sag effect of the track under the action of gravity.
- Durch Drücken der Spur auf die Stahlachse, um den Durchhang der Spur unter Einwirkung der Schwerkraft zu erzielen.
- Mediante el uso de eje de acero para presionar la pista para lograr el efecto de hundimiento de la pista bajo la acción de la gravedad.
- 通过使用钢轴压履带以达到履带在重力作用下的下垂效果。

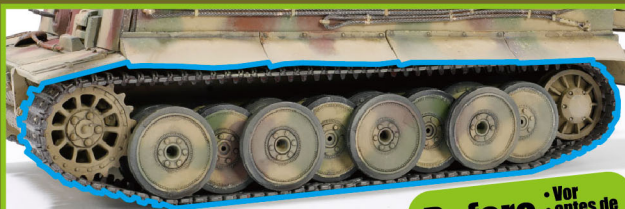

Before
• Vor
• antes de
• 原形状态

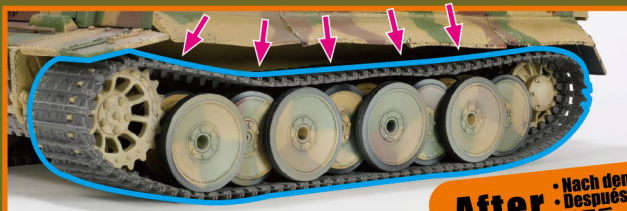

After
• Nach dem
• Después
• 效果后

1

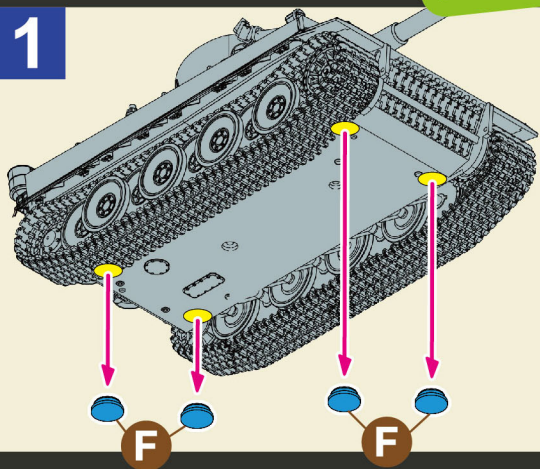

2

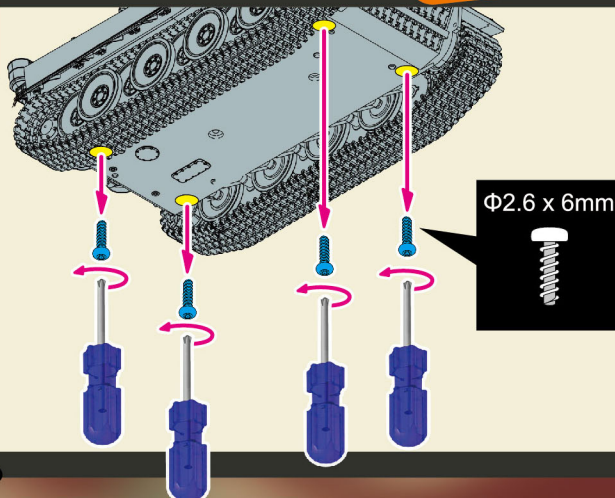

3

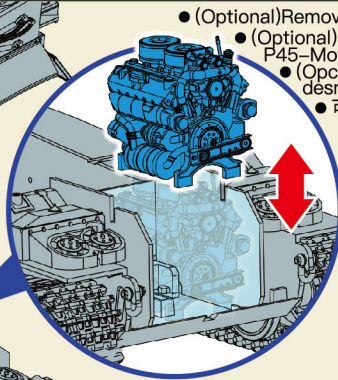
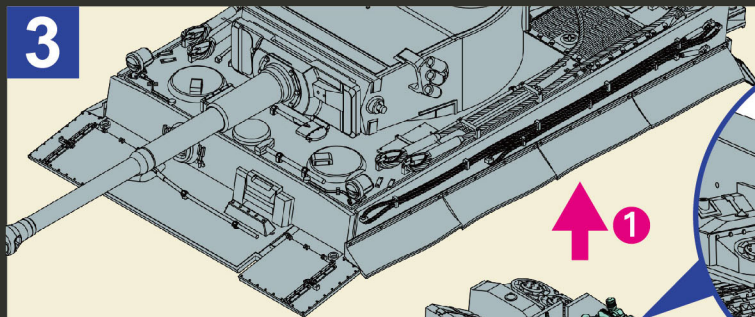

- (Optional)Removable Maybach HL210 P45 engine.
- (Optional)abnehmbarer Maybach HL210 P45-Motor.
- (Opcional) Maybach HL210 P45 desmontable.
- 可拆卸的迈巴赫HL-210P45发动机。

- **NOTE:** Move the steel shaft to the middle.
- **HINWEIS:** Bewegen Sie die Stahlwelle in die Mitte.
- **NOTA:** Mueva el eje de acero al medio.
- **注意:** 将钢轴移到中间。

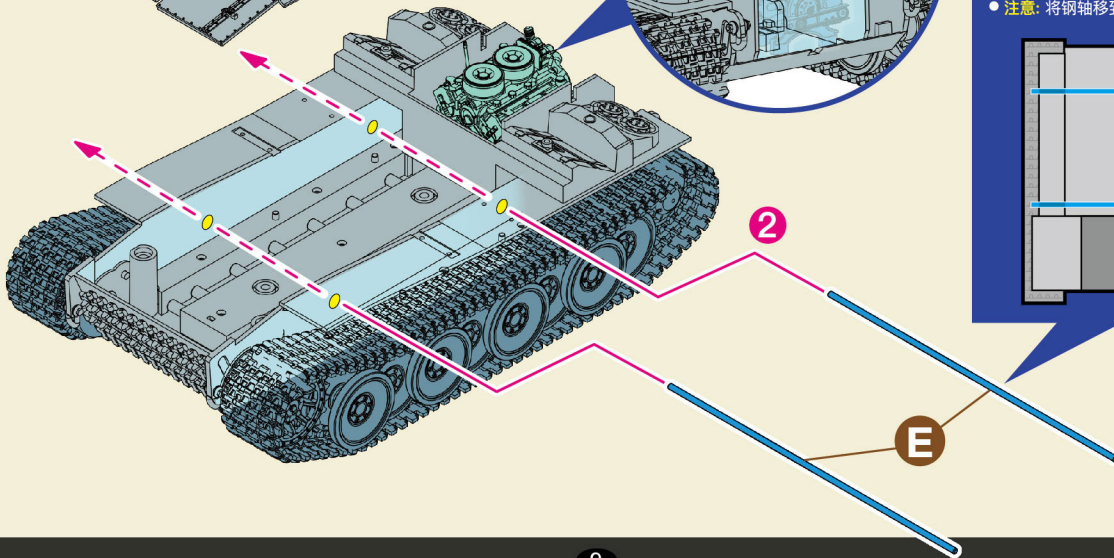
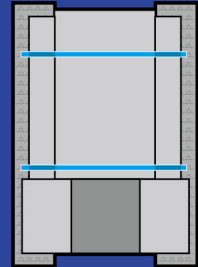

4

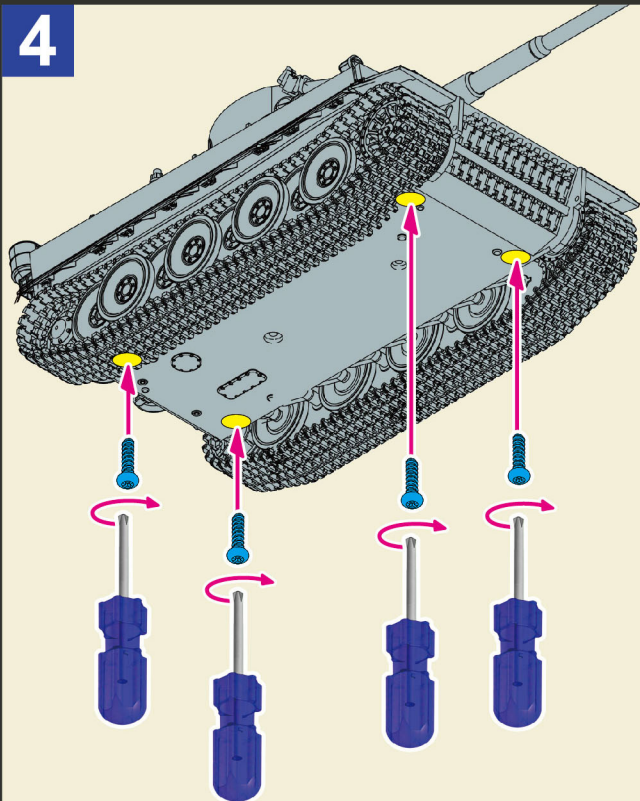

5

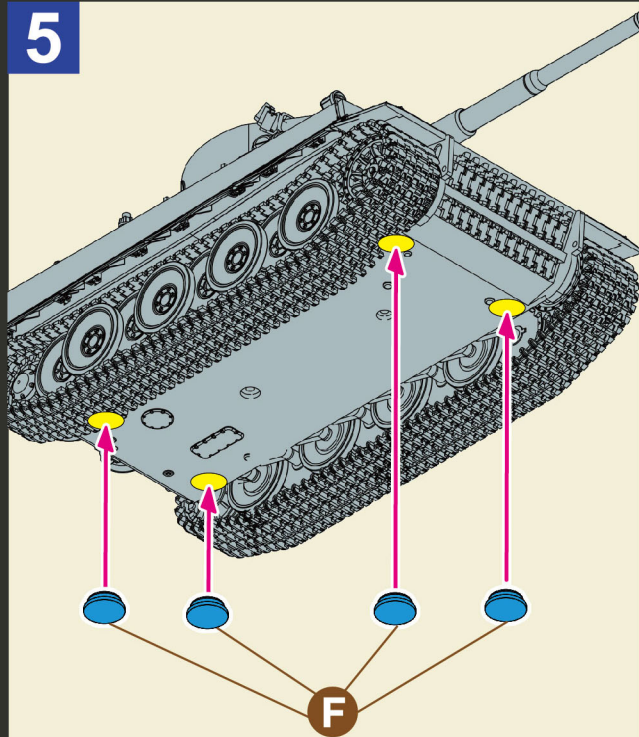



Finished

- Erledigt
- Terminado
- 完成



Schwere Panzerabteilung

505

Early Production



